

Food Quality and Shelf Life

(Shelf Life, Deterioration, & Packaging)

- **Definitions**
- **Mechanisms of deterioration**
- **Current role of packaging**
- **Examples of future concepts**

JH Hotchkiss
Cornell University

Objective

- **Describe the problems and needs related to food quality and shelf life.**

Food Quality

- Degree to which a food meets expectations
- “High” exceeds expectations
- “Low” does not meet expectations

Expectations for Food

- **“Taste” (appropriate sensory factors)**
 - Appearance, texture, taste, odor, auditory
- **Nutrition/Healthful profile**
- **Convenience & preparation**
- **Storage shelf life**
- **Intangible needs & benefits**
- **Physical structure**
- **Safety & environmental costs**

What is the Shelf Life of Milk?

- **Stored at room temperature.**
- **Aseptically processed and packaged.**
- **The shelf life of a food depends on**
 - **How it is processed**
 - **How it is stored**
 - **How it is packaged**

Shelf Life

- The **time** it takes a food product to **deteriorate** to an **unacceptable degree** under **specific** storage, processing, and packaging **conditions**.

Time to Deteriorate is Relative

- **Product composition**
- **Storage conditions**
 - temperature
 - atmosphere
- **Processing conditions**
- **Distribution conditions**
- **Initial quality**
- **Packaging**

Shelf Life Plots

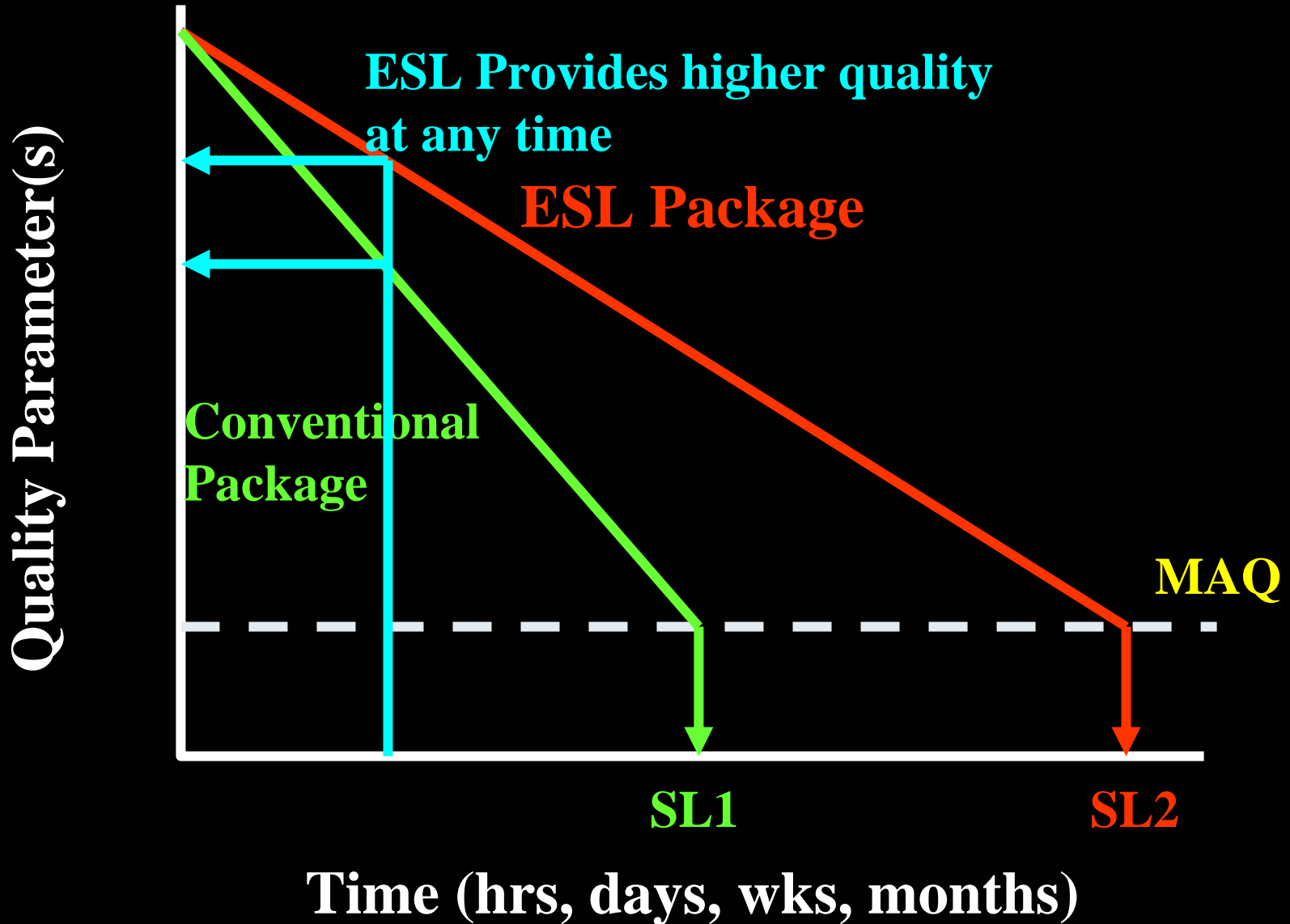

Selected Measurable Food Quality Factors

- **Microbial counts and types**
- **Nutrient content**
- **Color & appearance**
- **Moisture content**
- **Physical shape/size**
- **Mechanical properties**
- **Flavor panel score**
- **Toxicant level (chemical risk)**
- **DAL (e.g. insect fragments)**

Setting Minimum Acceptable Quality

- **Regulatory limits (e.g. 20,000 cfu/ml)**
- **Just noticeable difference (JND)**
 - **Sensory**
 - **Expert vs. consumer**
- **Customer complaints**
- **Detected by >50th percentile of consumers**
- **MAQ IS A MANAGEMENT DECISION**

Modes of Food Deterioration

- **Biological**
 - **Microorganisms**
 - **spoilage**
 - **pathogenic**
 - **Vermin**
 - **insects**
 - **rodents**

Modes of Food Deterioration

- **Chemical**
 - **Oxidation**
 - **Flavor deterioration**
 - **Color change or loss**
 - **Vitamin loss**
 - **Chemical contamination**
 - **Enzymatic**

Modes of Food Deterioration

- **Physical**
 - **Moisture gain or loss**
 - **Breakage or clumping**
 - **Textural changes**
 - **Contamination (objects)**

Motivations for Extending Shelf Life

- **Reduce distribution costs**
- **Enter new markets**
- **Non-traditional distribution channels**
- **Improve quality**
- **Reduce restocking costs**
- **Provide longer code dates**

Peanut Snack Shelf Life

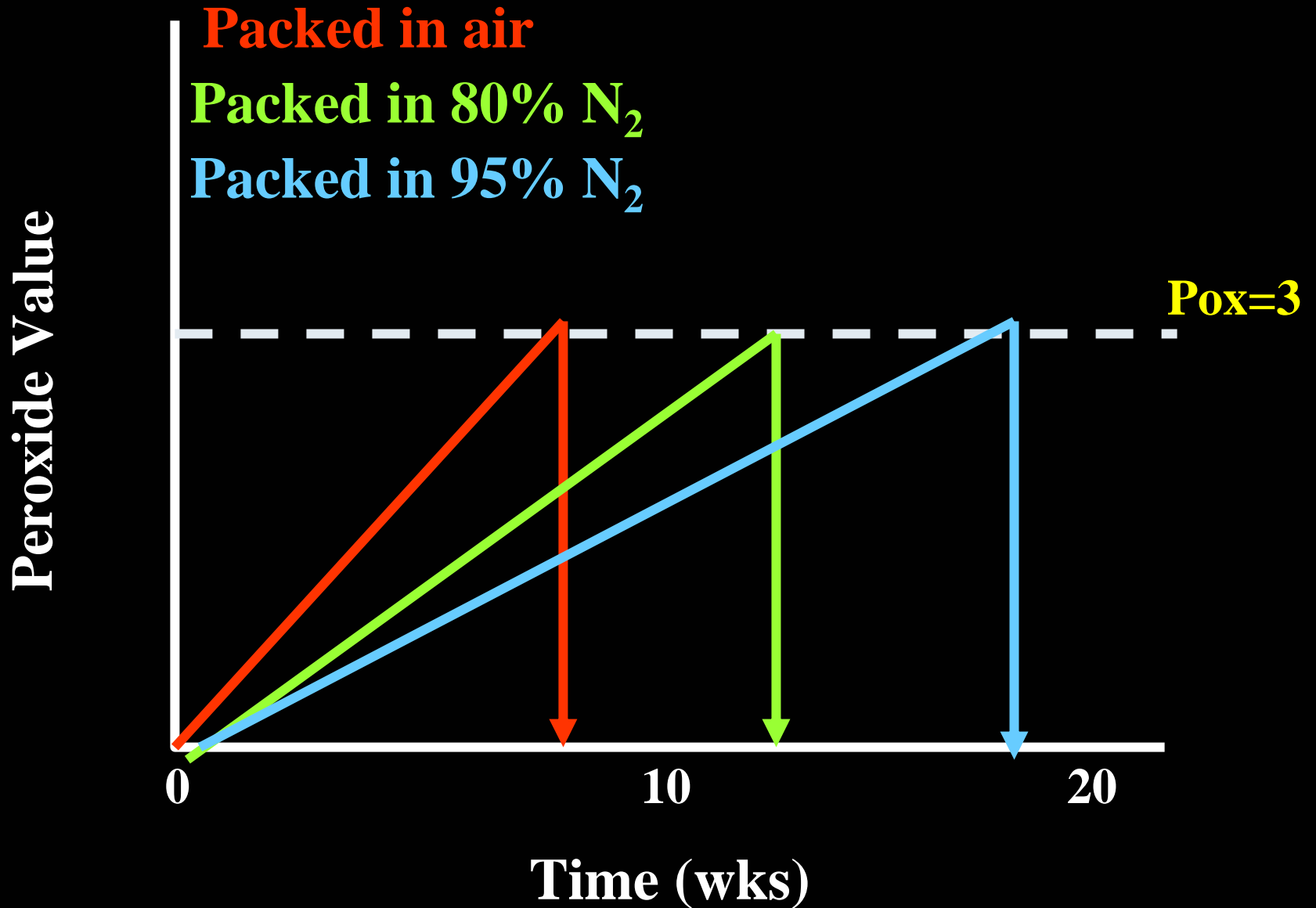

Major Goal of Packaging

- **Reduce the rate of quality loss**
- **Increase the shelf life of the product**

Recent Packaging Technologies to Extend Shelf Life

- **Higher barrier packaging**
- **Modified atmosphere packaging (MAP)**
- **Direct addition of CO₂ to products**
- **Broader use of irradiation**
- **New processes (e.g. high pressure, ohmic, pulsed light, etc.)**

Question: In what ways could packaging improve food quality and shelf life beyond current technologies?

What new packaging materials or methods could be developed which would improve quality and shelf life?

What research is needed to affect these improvements?

Examples of Emerging Packaging Technologies Which May Extend Shelf Life

- **Antimicrobial Materials**
- **Bio-Active Materials**
- **Selective & Adjusting Barriers**
- **Indicating & Sensing Materials**
- **Flavor Maintenance & Enhancing Materials**

Example:

Antimicrobial Packaging

Nisin Impregnated Antimicrobial Film/Paper

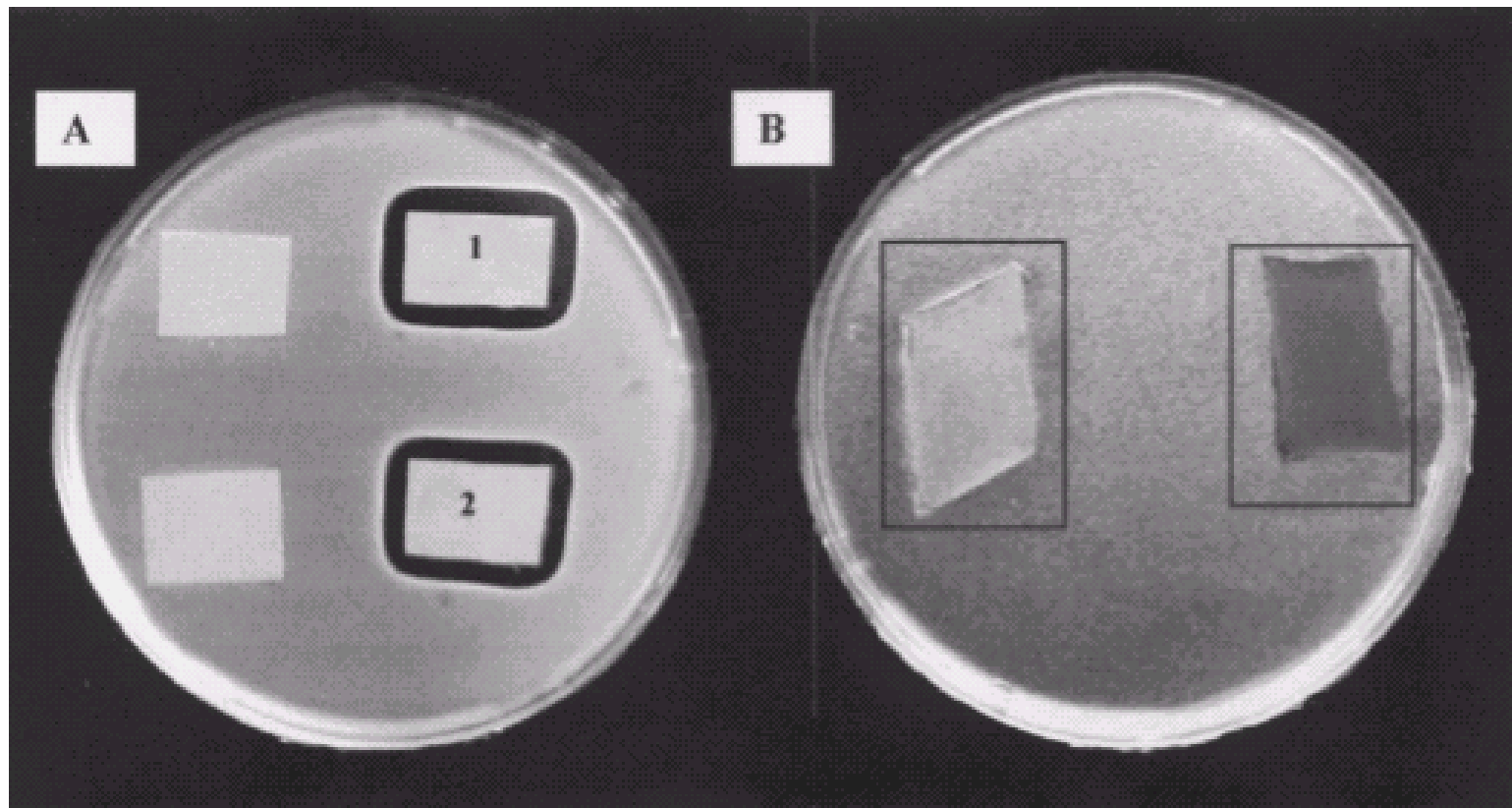
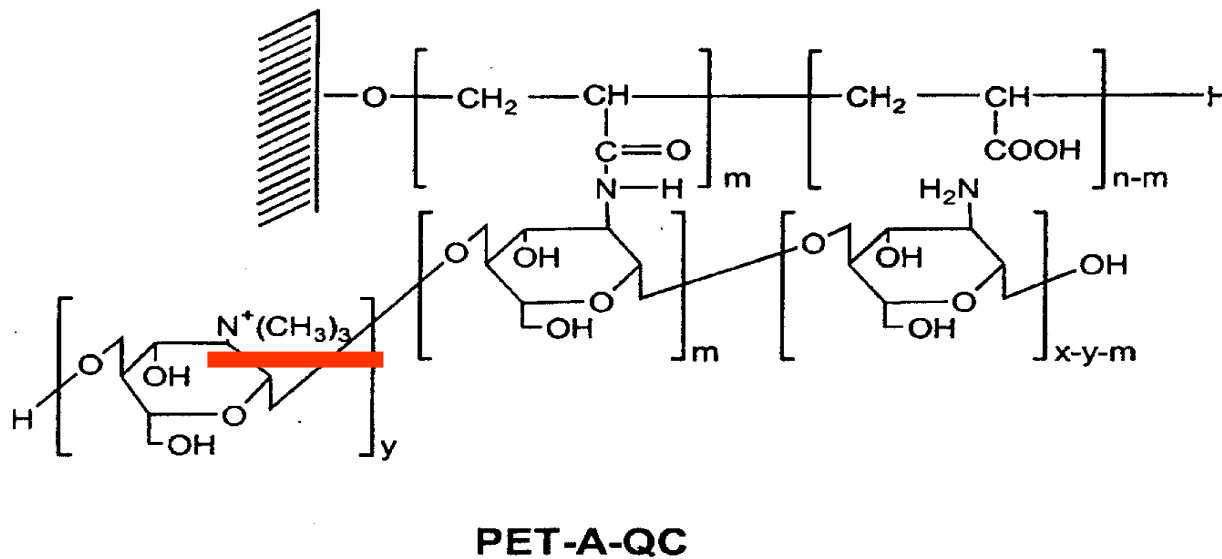
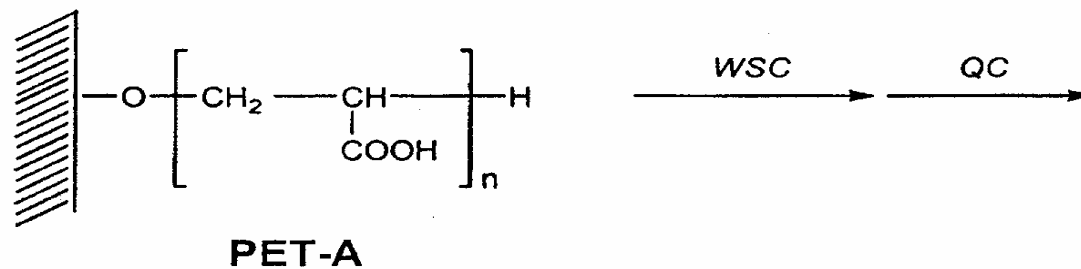
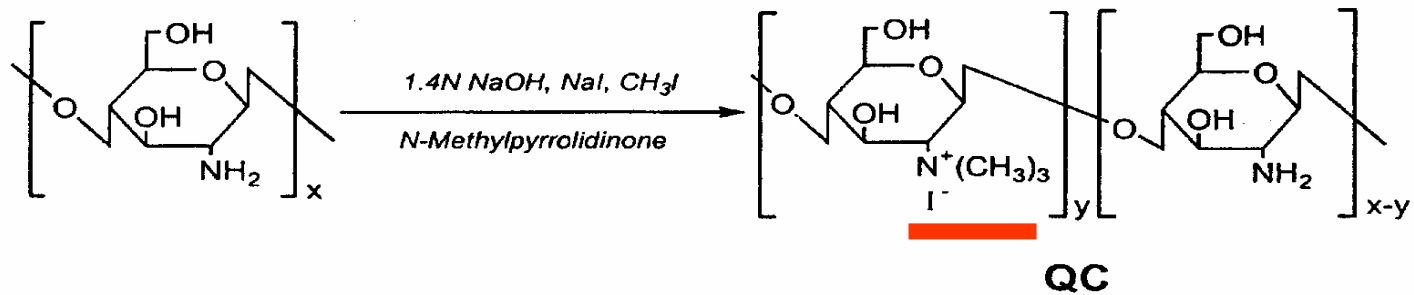

Fig. 2. Growth inhibition of *Lactococcus lactis* HP by Nisaplin[®] immobilised on cellulose-based packaging material prepared with lactacin 3147 (A1) and nisin (A2) and plastic prepared with nisin (B). Controls prepared without bacteriocins are shown on the left of each picture.



Scheme 3 Schematic diagram showing the quaterization of chitosans and their immobilization on PET-A.

Antimicrobial Peptides

Immobilization on PS Beads

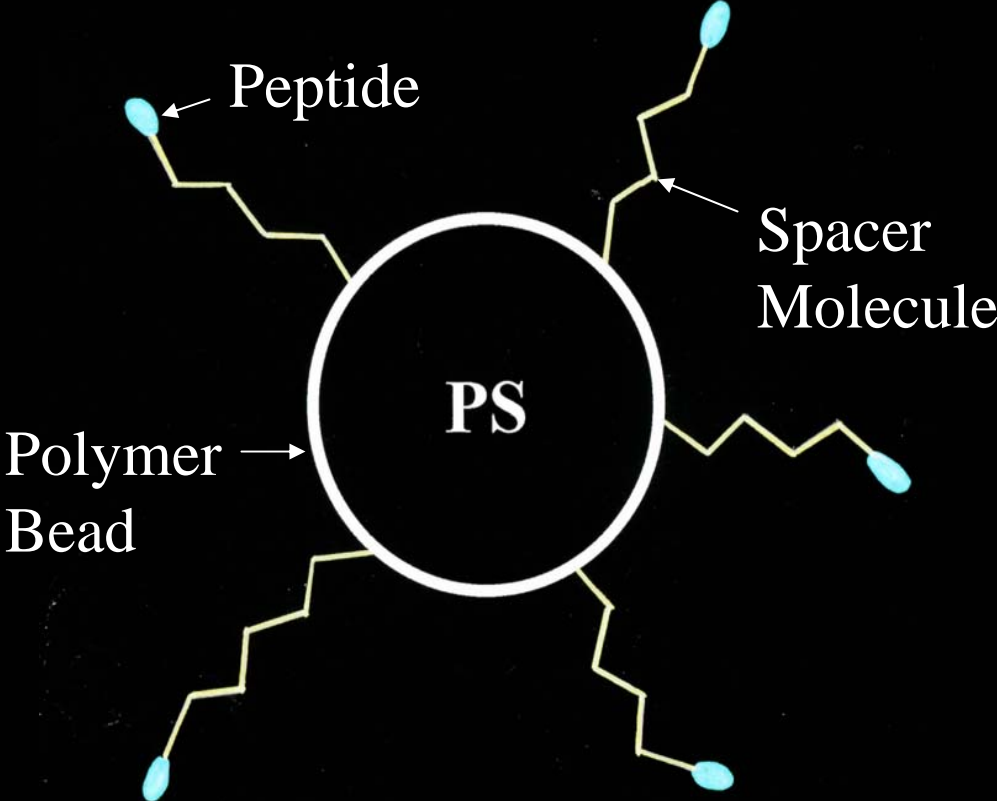

Concentration (mg/ml) of SMPS required to give a 3 log reduction in counts in buffer in 10, 30, or 60 min at 25°C

<u>ORGANISM</u>	10 MIN	30 MIN	60 MIN.
• <i>E. coli</i> 0157:H7	8	5	4
• <i>S. typhimurium</i>	18	17	8
• <i>S. liquefaciens</i>	8	5	ND
• <i>P. fluorescens</i>	7	5	3
• <i>B. subtilis</i>	3	3	2
• <i>L.monocytogenes</i>	12	5	3
• <i>S. aureus</i>	>60	57	50
• <i>K. marxianus</i>	16	9	8

Example: Selective/Adjusting Barrier Films

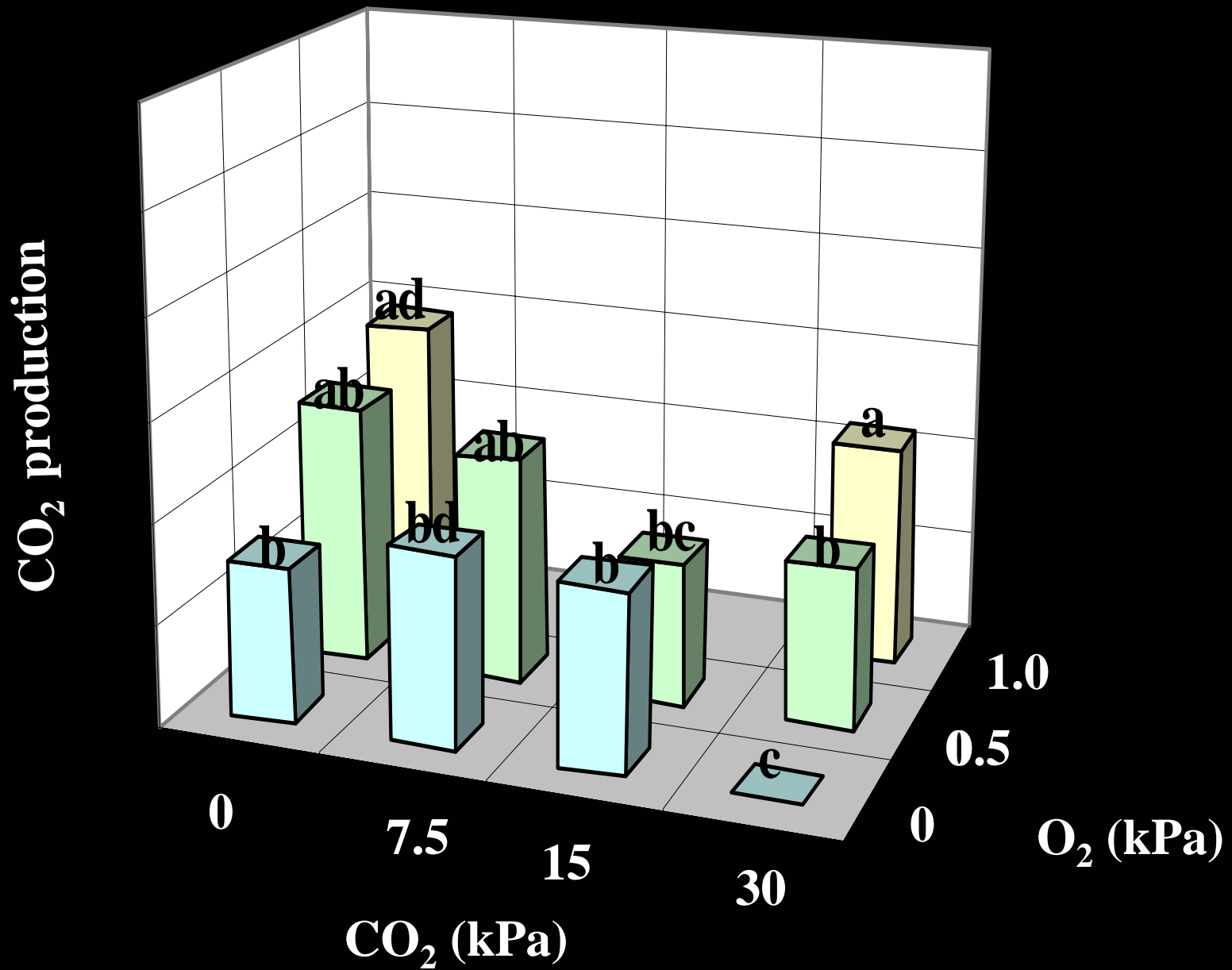

Effect of Atmosphere on Cut Apple Respiration

Gurbuz & Hotchkiss, 2001

Optimizing Film Permeation for Cut Fruits and Vegetables

- Senescence and decay are closely related to
 - temperature
 - ethylene exposure
 - composition of the surrounding atmosphere
- Atmosphere composition relates to
 - respiration rate
 - package permeability & Permselectivity
 - film permeability & area/product mass ratio

Permselectivity

Permselectivity (β) = ratio of CO_2 permeability coefficient (P_{CO_2}) to O_2 permeability coefficient (P_{O_2}), $\beta = P_{\text{CO}_2}/P_{\text{O}_2}$

Perm Selectivity & Cut Apples

**Under optimum atmosphere of 30% CO₂, 0.5% O₂;
R_{CO₂} = 2.1 Kg/hr, and RQ = 1.9 (Gunez & Hotchkiss, 2001).**

**Assume: Package A= 1320 cm²; x= 1 mil; mass apples = 2.27 Kg;
bulk apple volume = 3818 cm³; package volume = 5090 cm³; and
headspace = 1272 cm³; optimum CO₂; y_{oCO₂} = 0.30; O₂; y_{oO₂} = 0.005;
external CO₂ and O₂ concentrations; y_{eCO₂} = 0; and y_{eO₂} = 0.21.
Calculated (Exama et al, 1993) required permeability for fresh-cut
apples is:**

$$\mathbf{P^R_{CO_2} = WR_{CO_2}L/Ap(y_oCO_2 - y_eCO_2) = 1.2 \times 10^{-2} \text{ mL mil/cm}^2 \text{ hr atm}}$$

$$\mathbf{P^R_{O_2} = WR_{O_2}L/Ap(y_eO_2 - y_oO_2) = 9.23 \times 10^{-3} \text{ mL mil/cm}^2 \text{ hr atm}}$$

$$\mathbf{P^R_{CO_2} / P^R_{O_2} = 1.3}$$

Permselectivities of Some Common Films

<u>Material</u>	<u>Perm Coeff. Permselectivity</u>		
	<u>CO₂</u>	<u>O₂</u>	<u>CO₂/O₂</u>
LDPE	99	27	3.7
PP	58	9	6.2
PVC	0.65	0.19	3.4
Cell. Acetate	348	10	34
PET	53	6.1	8.7
Ionomer	—	--	4.2
Nylon 6	1.6	0.38	4.2

Al-Ati & Hotchkiss, 2001

Recommended Gas Composition for Fruits and Permselectivity of Plastic Films

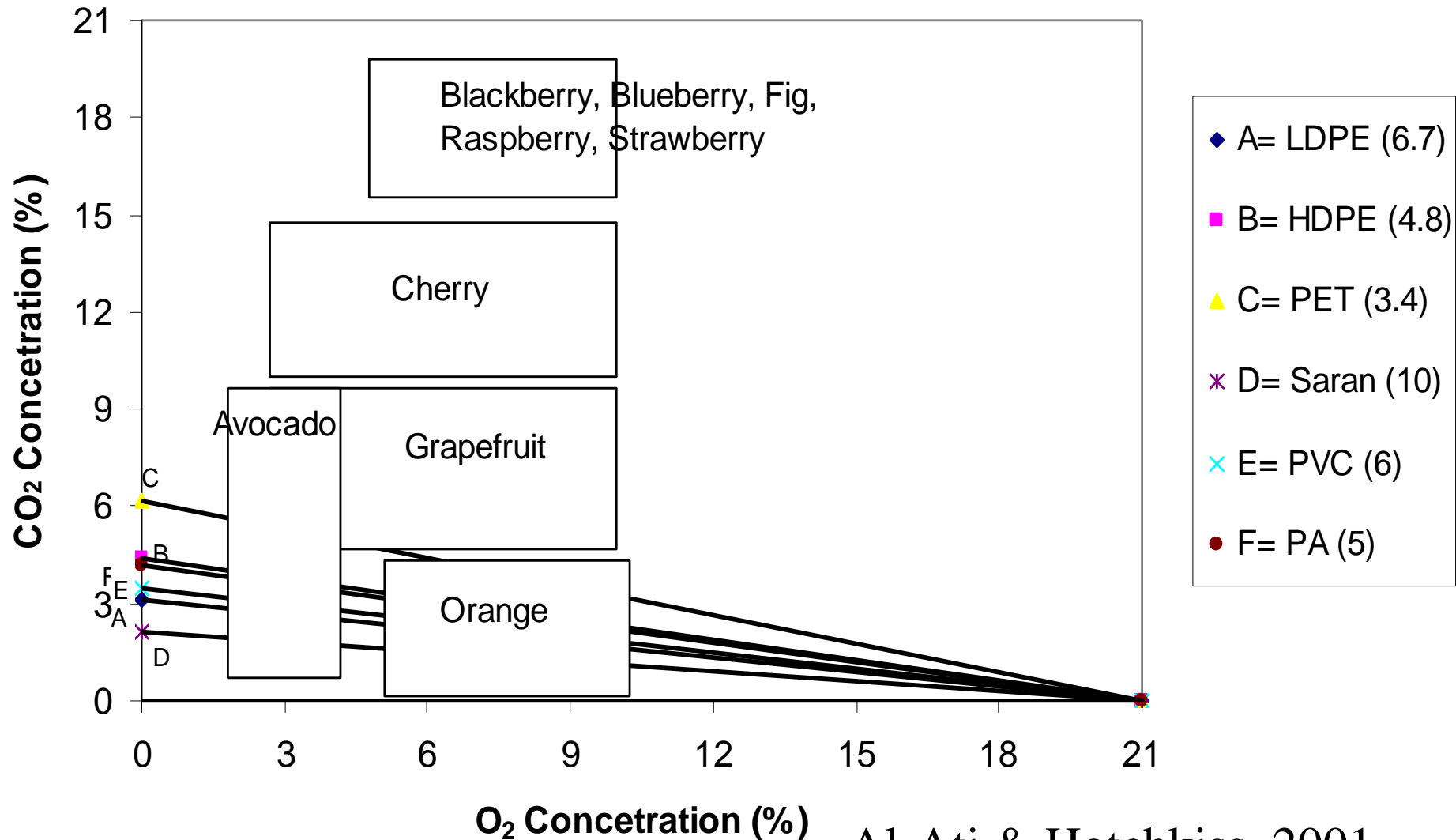

Example: Microbial Condition

ANTIBODY GRID

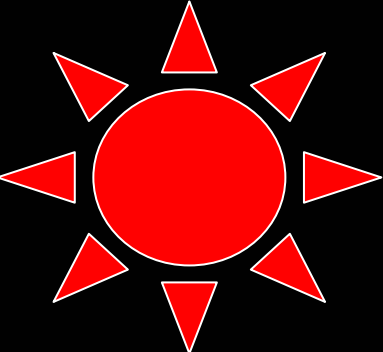

LASER

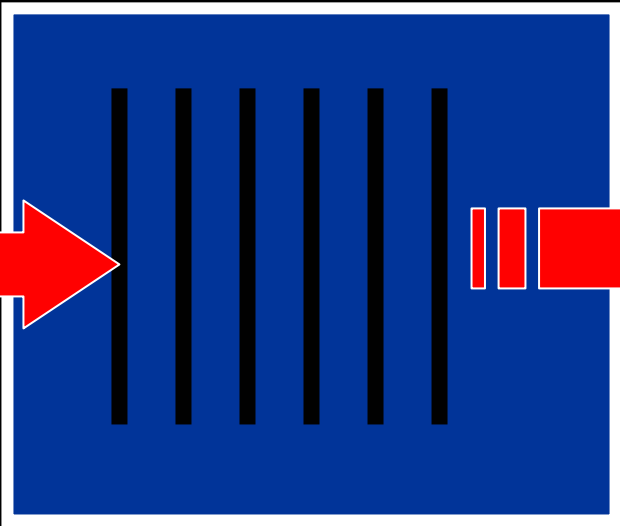

**DIFFRACTION
PATTERN**

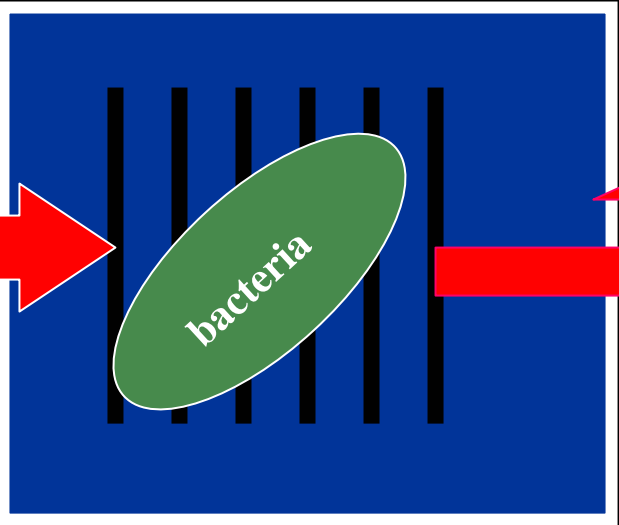
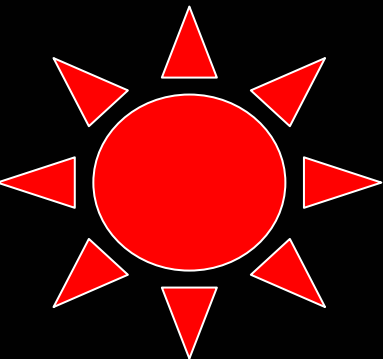

bacteria

THE END

Conclusions

- **Packaging plays a central role in reducing the rate of quality loss in foods.**
- **There is a need for technologies that reduce the rate of food deterioration and/or provide information about the quality/safety of foods.**
- **Research & development will be necessary to affect these desirable changes.**