

# STATE OF THE ART OF ACTIVE/INTELLIGENT FOOD PACKAGING

---

Aaron L. Brody  
Packaging/Brody, Inc.  
P O Box 956187  
Duluth, Georgia 30095 USA

Institute of Food Technologists  
Food Packaging Summit  
7-9 May 2006



# OVERVIEW

---

- Definitions
- Active packaging
  - Moisture
  - Oxygen
  - Ethylene
  - Microbiological
- Intelligent packaging
  - Temperature
  - Location
  - Microbiological status



# CONCLUSIONS

---

- Developmental
  - Many good laboratory results
  - Relatively little commercial application
    - Cost
    - Accuracy
    - Adverse secondary effects
- Commercialization has been relatively slow
  - Purge, moisture control
  - Oxygen removal
  - Time temperature integrators
  - Location/identification



# CONCLUSIONS

---

## □ Potential for future

- Combine moisture control with antimicrobials
- Inventory monitoring
- Interaction of package with home and food service appliances
- Temperature data
- Reduced oxygen to prolong biochemical shelf life
- Stimulates enhanced barrier packaging



# NEEDS FOR FUTURE

---

- ❑ Improved communication among academic, industry and others involved
- ❑ A single independent objective resource to objectively evaluate developing technologies
- ❑ Closer targeting of longer term commercial needs



# ACTIVE PACKAGING

---

- Active packaging is sensing followed by the overt manipulation of the environment in the package to better retain food content microbiological or biochemical quality
  - Purge absorbers
  - Microwave susceptors
  - Oxygen scavengers
  - Oxygen additions
  - Moisture absorbers or emitters
  - Odor absorbers or emitters
  - Anti or counter microbials
  - And other controllers of active variables



# INTELLIGENT PACKAGING

---

- An intelligent package senses change and communicates that information to can provide benefits (such as more convenience, better safety, or higher quality) if used.
- Examples
  - Time-temperature, etc. indicators can imply/signal user the quality of the packaged product
  - Biosensor in theory can inform the user of the presence or growth of microorganisms, spoilage and even pathogenicity in the package
  - Bar or PDF code can help to provide better reheating and/or cooking
  - Ripeness
  - Nutritional attributes
  - Gas concentrations in modified atmosphere packages



# ACTIVE PACKAGING

---

- Moisture control
  - Desiccants for dry food
    - Internal
    - Multiphase plastic for both pre and post opening activity
  - Humidity controllers
    - For high moisture foods, e.g. cut fruit, vegetables
    - To retard moisture loss
    - To retard excess moisture in headspace and interstices where microorganisms can grow
  - **Integrate moisture control with other active packaging functionalities**
    - e.g., antimicrobials, pH controllers, oxygen removers



# Active Packaging

---

- Purge absorption
  - To remove liquid squeezed or leaking from fresh products such as meat, poultry and fruit
    - Unsightly
    - Medium for microbiological growth
    - Odor generating
    - Leaks into consumer environment: source of major consumer complaints
  - Controlled by pulp or polymers



# Active Packaging

---

- Purge absorption
  - Can be enhanced by active additives
    - Antimicrobials
    - pH reducers
    - Carbon dioxide generators
  - The largest commercial application of active packaging although not always classified as active packaging



# Purge Absorbers- Pulp

---



# Maxwell-Chase Polymeric Purge Absorbers

---



# CONTROLLED PURGE FRUIT PACKAGE

---



# ACTIVE PACKAGING

---

- Moisture control
  - Desiccants for dry food
    - Internal adjuncts
      - Porous sachets or perforated plastic cartridges
      - Mostly for pharmaceuticals for long term preservation
    - Incorporate into plastic package
      - Plastic is partial moisture barrier
      - Multiphase plastic for both pre and post opening activity
        - Largely for multi-use drugs/testing devices



# MINIPAX® SORBENT PACKETS

---



MiniPax® Sorbent silica gel packets are formed of heat sealed Tyvek® spunbonded polyolefin.



# Active Packaging

---

## Humidity controllers

- For high moisture foods, e.g. cut fruit, vegetables
- To control in-package relative humidity
- To retard moisture loss
- To retard excess moisture in headspace and interstices where microorganisms can grow
- Infrequently used



# ACTIVE PACKAGING: OXYGEN REMOVERS

---

- Oxygen scavengers
  - To remove oxygen and retard oxidative reactions
  - As sachets in headspace
    - Jerky
    - Pepperoni
    - Pasta
    - Bakery goods
  - As labels – with less quantity of active component
  - Incorporated into package materials
    - Plastic beer bottles
    - Pasta
    - Retortable pouches and trays



# OXYGEN SCAVENGERS

---

- Mitsubishi Gas Chemical Ageless; Multisorb Technologies, etc., oxygen absorbers
  - Ferrous oxide in Tyvek spun bonded polyolefin sachets
  - Water vapor activated
  - “Rusted” to ferric oxide by reacting with environmental oxygen
  - In excellent oxygen barrier primary packages, removes residual and entering oxygen
  - Used widely in Japan for dry meats, bakery goods, nuts
  - Not overly successful in North America or Europe
- Ascorbic acid, sulfites, photosensitive dyes, unsaturated hydrocarbons and ligands
- Oxbar™ cobalt catalyzed nylon MXD6 imbedded in the plastic structure



# Mitsubishi Ageless® Oxygen Absorber



## Comparison Effect of AGELESS

Pizza Crust

After 5 days @ 25°C.

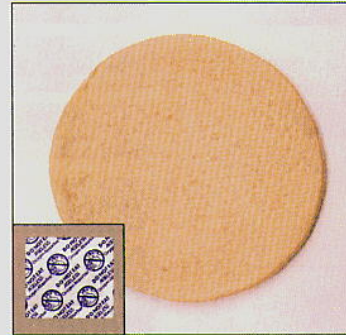

AGELESS packet

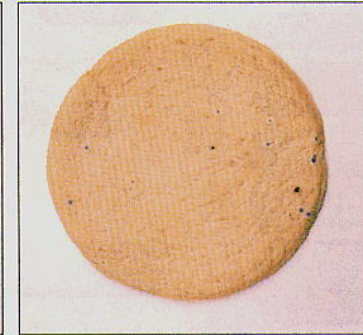

Control

After 20 days @ 25°C.

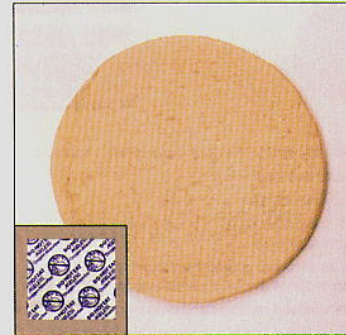

AGELESS packet

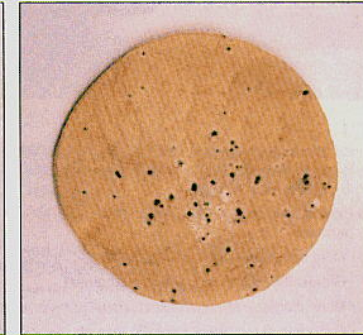

Control



# MULTISORB OXYGEN ABSORBERS



FreshPax™ Packets and Strips are designed to absorb oxygen inside sealed packaging to less than 0.01%



FreshMax™ Label is designed for adhesion with high value foods where oxygen absorption requirements are at levels below 50 cc.



# Oxygen Scavenger Label

---

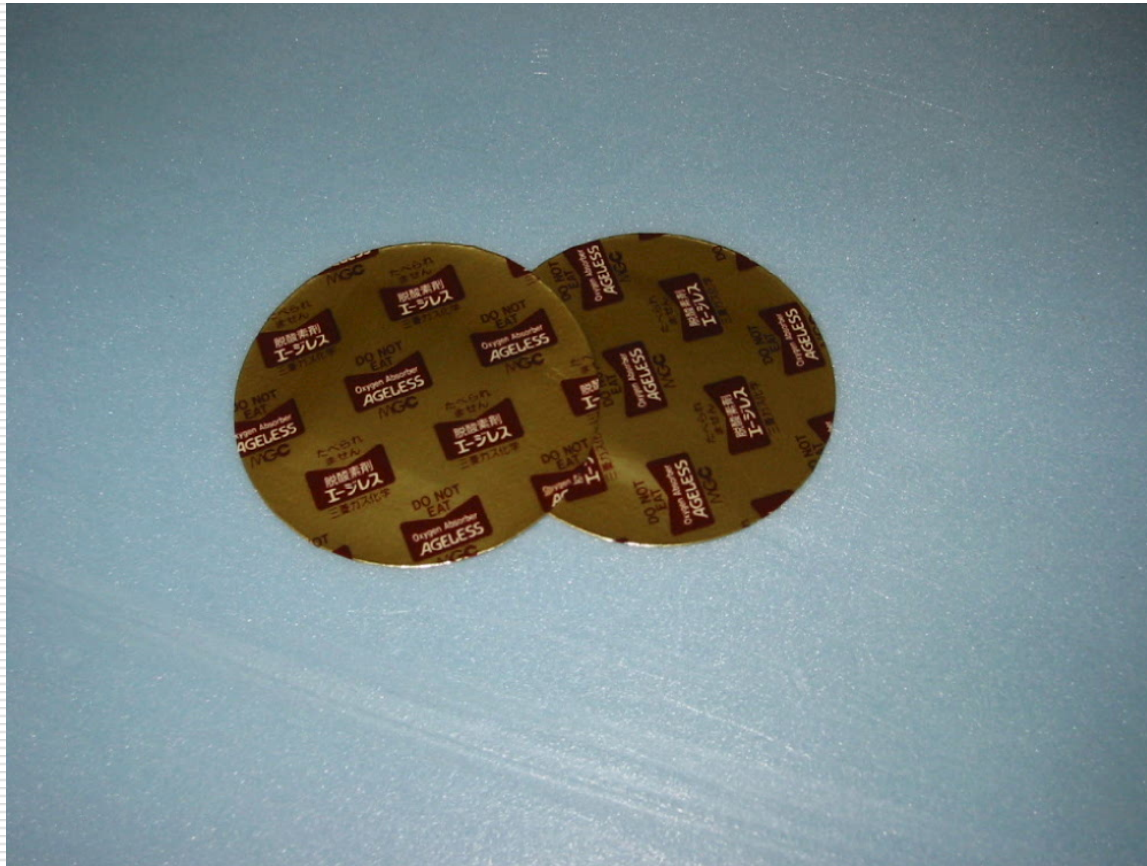

# OXYGEN SCAVENGERS

---

- Chevron Phillips OSP oxygen scavenging polymer
  - EMCM: Benzoacrylates
  - No resulting odor from oxidation reaction
  - Basis for current Cryovac OS2000
    - Incorporated in film
    - Lidding on Barilla moist pasta, processed meat trays
  - Ultraviolet energy triggered
  - Claimed capable of reducing oxygen to 4-10 ppm
  - Departing the business



# Oxygen Scavengers

---

- Starshield
  - Crown Cork and Seal
  - Constar
  - PET bottles
    - Multilayer preforms
    - PET/5 % Oxbar/PET
    - Oxbar=MXD6 nylon + Cobalt catalyst
    - For beer and juice
- Continental PET Technologies  
MXD6 nylon + Cobalt catalyst



# PET BEER BOTTLE WITH OXYGEN SCAVENGERS

---



# Oxygen Scavengers

---

- Amcor PET
  - Bind-Ox
  - Amguard multilayer preforms
  - PET bottles
  - Beer and juices



# Oxygen Scavengers

---

## BP Chemicals

- Amosorb ferrous iron
- Licensed by Color Matrix
- PET bottles
  - Monolayer or multilayer

## Bericap

- One piece bottle closure with multilayer oxygen sulfite scavenger



# Oxygen Scavengers

---

- O-Ox
  - Snappy Apple
  - Claims 5X oxygen removal rate
  - Ferrous iron based concentrate
  - For plastic beer bottles



# Oxygen Scavengers

---

## □ Honeywell

- Blend scavenger with nanocomposite to enhance barrier
- Aegis Ox – OXCE
- Removes oxygen
- Restricts oxygen AND carbon dioxide
- Plastic beer bottle



# Oxygen Scavengers

---

- Actituf
  - Monolayer PET
  - Liquid activated+passive barrier
  - Plastic beer bottles
- Unsaturated hydrocarbon butadiene: produces off odors
- Glucose oxidase
  - Nutraceuticals
  - Can simultaneously produce carbon dioxide as an antimicrobial



# Oxygen Scavengers

---

## □ Huhtamaki

- Combine scavenger with EVOH
- Grey color

## □ Hsaio Sung – Taiwan

- O-buster ferrous iron
- For consumer use
- Sachets



# Oxygen Scavengers

---

## Ciba

- Shelfplus
- Ferrous iron based
- Now combining with EVAL's EVOH
  - Bebo Plastik
- For polypropylene and even polyethylene
  - Semi-rigid containers
  - Retort trays



# Oxygen Scavengers

---

## □ Mitsui – Japan

- Wonderkeep
- Integrate with RFID

## □ Wipak

- Combitherm
- Multilayer of scavenger and EVOH



# ADD OXYGEN

---

- To retard respiratory anaerobiosis
  - Responsive to temperature
  - Intellipack™ increases/controls package gas permeability to permit entry of air as a function of temperature
- To retard respiratory anaerobic pathogenic microbiological growth
- To retard respiration in cut lettuce: > 70 % oxygen
  - Oxygen generating chemicals in package structure
  - From Atco, France
- To “control” oxymyoglobin red color in fresh meat
- But does the oxygen reach into pockets and interstices?



# CARBON DIOXIDE CONTROL

---

- Add carbon dioxide from package structure to carbonated beverages to compensate for losses due to insufficient gas barrier
- Add carbon dioxide to increase internal environmental gas to suppress microbiological growth
  - A sub-set of modified atmosphere packaging
  - From plastic package structure
  - From moisture-activated chemicals in sachets, absorbent pads, etc.
- Remove excess carbon dioxide from fast respiring produce using very high gas permeability plastic
  - Asparagus



# OTHER ACTIVE PACKAGING CONCEPTS

---

- Odor scavengers
  - Remove trivial amounts of odor such as from initial lipid or plastic oxidation from package headspace
  - Activated carbon
    - Most effective
    - Best when on interior surface
      - Multiphase plastic
  - Cyclodextrins
  - Molecular sieves
  - Alpha tocopherol (vitamin E)
  - Polyethylene imide aldehyde scavengers



# ODOR CONTROL

---

- Aroma additions
  - Enhance the product sensory attributes
  - May be incorporated into plastic
    - Continuous emission
    - Activated by physical activity
  - May be on plastic surface
  - May be independent device such as an impregnated straw or closure
  - Activate on opening



# ETHYLENE ABSORBERS

---

- Ethylene is respiratory gas from fresh produce
  - also from engine exhaust fumes
- Excess ethylene accelerates respiration
- Remove ethylene extend shelf life
  - Physical absorption
    - On active surfaces
      - Activated carbon
      - Zeolite
  - Chemical removal with permanganate
    - Effective and commercial – in bulk distribution



# ACTIVE PACKAGING: ANTI-MICROBIAL

---

- Antimicrobial or countermicrobial
  - Objective is to reduce the rate of growth of spoilage and/or pathogenic microorganisms in the contained food and thus extend the shelf life
  - Technologies under study
    - Silver ion
    - Allyl isothiocyanate
    - Chlorine dioxide
    - Antibiotics
    - Organic acids
    - Ethyl alcohol
    - Natural spices and essential oils
  - None commercial for food packaging in United States



# ANTI-MICROBIALS

---

- Silver salts
  - Direct contact
  - Slow migration
  - React with organics preferentially
  - Broad spectrum effectiveness
  - Surface effects primarily
  - Few, if any, secondary effects



# ANTI-MICROBIALS

---

## □ Ethyl alcohol

- Adsorbed on silica or zeolite
- Emitted by evaporation
- Somewhat effective
- Secondary odor
- Regulatory restrictions
- Consumer concern
- Used in past for soft bakery goods



# ANTI-MICROBIALS

---

- Chlorine dioxide
  - Widely publicized
  - Precursor in package structure
    - Reacts with water to produce  $\text{ClO}_2$
    - $\text{ClO}_2$  is vapor and can permeate product
  - Broadly effective against microorganisms, but weak
  - Adverse secondary effects
    - Meat color darkening
    - Green vegetable bleaching
  - Principal advocate no longer in business



# ANTI-MICROBIALS

---

- Allyl Isothiocyanate (AIT)
  - Active component in wasabi, horseradish, mustard
  - Broad spectrum anti-microbial, antimycotic
  - Strong secondary odor effects
    - Possible amelioration by vanillin
- Other essential oils
  - Clove, carvacrol, thymol, cinnamon, etc.
  - Diacetyl



# AND MORE ACTIVITY FOR THE FUTURE

---

- ❑ Heat the contents on demand: self heating
- ❑ Chill the contents on demand: self chilling
- ❑ Both of the above have been commercial
  - At a cost
    - ❑ Money
    - ❑ Space
- ❑ Sense the temperature and control the content temperature
  - To compensate for the deficient distribution system (cold chain)



# Self Heating Packaging

---



# Self Heating Packaging

---

- Calcium oxide + water exothermic reaction
  - Magnesium oxide + water exothermic reaction
- For coffee) cans
  - Polypropylene barrier
  - Wolfgang Puck
  - Retorted
  - 6-8 minute heating time after activation
- Military rations
- On the go meals
- Heating device occupies large space volume



# Self Heating Coffee Can

---



# Self-Cooling Packaging

---

- Evaporation of external compound removes heat from contents
  - Freon – not environmentally sound
  - Carbon dioxide – pressurized
  - Water evaporated and adsorbed on surfaces –
    - Functional and commercial for beer kegs
    - Reversible



# ACTIVE PACKAGING: MICROWAVE BROWNING

---

- Packaging devices to achieve surface browning and crusting in rapid heating microwave oven environment
- Limited technical ability
- Limited market success
  - Bakery goods
  - Finger foods
  - Popcorn popping adjunct



# Susceptors



Susceptor materials consisting of a metallized coating at optical density of around 0.25.



# SHIELDING WITH REFLECTORS

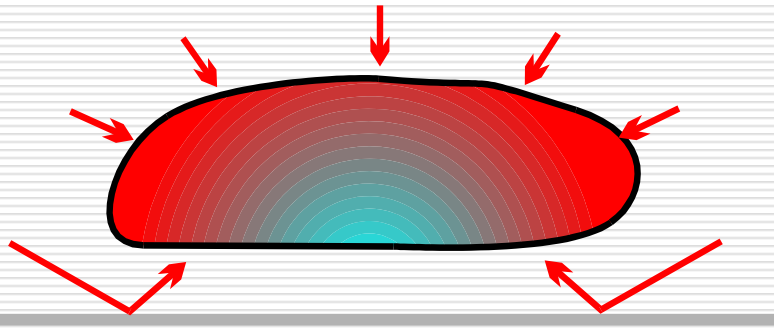

Without Shielding  
(Over-exposure of the edges)

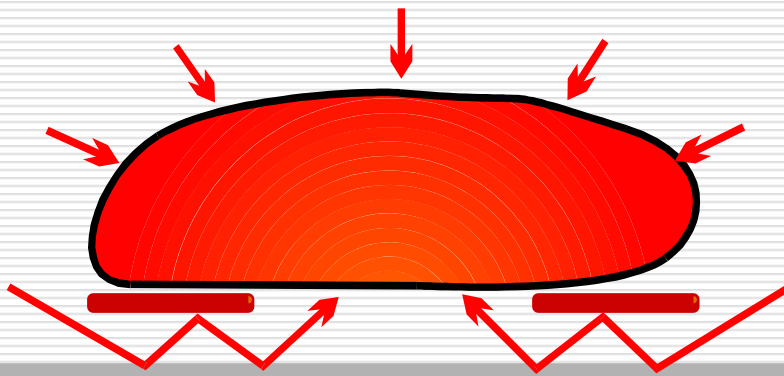

With Shielding  
(Reflector shields the edges and redirect the power to the center)



# MICROWAVEABLE PIZZA WITH SUSCEPTOR, SHIELDING AND FOCUSING

---



# INTELLIGENT PACKAGING

---

- If you can measure a variable, you can probably control it
- Location Indicators
  - The current classical application for Radio Frequency Identification (RFID)
  - For distribution inventory control
    - Site
    - Time
    - Quantity



# Intelligent Packaging

---

## □ Technologies

- Oxygen scavenging with integrated monitoring
- Ethylene scavenging with integrated monitoring
- Microwave ready
- Thermochromic inks
- Barrier plus integrated monitoring
- Self-heating/cooling plus monitoring



# INTELLIGENT PACKAGING: TEMPERATURE EXPERIENCE

---

- Temperature indicators
  - Time temperature integrators
    - Commercial and in use
    - Significance of TTI data re: shelf life, quality, etc.
    - Required for military rations and some pharmaceuticals
    - Cost
  - Maximum temperature, i.e., threshold, indicators
    - Commercial and in use
    - Mostly for heating
    - Some for refrigerated, frozen foods, ice cream



# CURRENT COMMERCIAL TTI PRODUCTS

---

- LifeLines Fresh-Check
  - Based on polymerization reaction
- 3M Monitor Mark
  - Based on dye diffusion
- Vitsab<sup>®</sup> TTI (Cox Technologies)
  - Based on enzymatic lipase color change



# Lifelines' Fresh Check Indicators



Fresh Check indicator is printed in a bull's-eye configuration

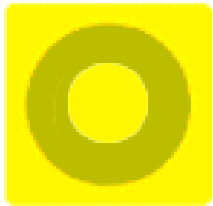

**Fresh**

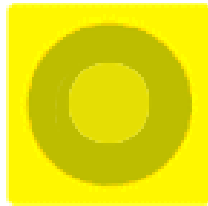

**Fresh**

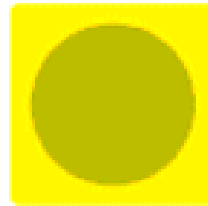

**Still Fresh  
Consume Immediately**

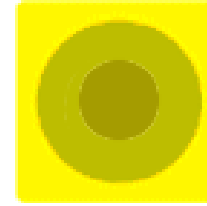

**Freshness No  
Longer Guaranteed**

Lifelines' Fresh Check indicators are color-changing, self-adhesive labels which respond to cumulative exposure to temperature. The indicator center irreversibly darkens, faster at higher temperatures. Price ranges from US \$0.025 – 0.035 each.



# 3M MONITOR MARK TEMPERATURE LIMIT INDICATORS

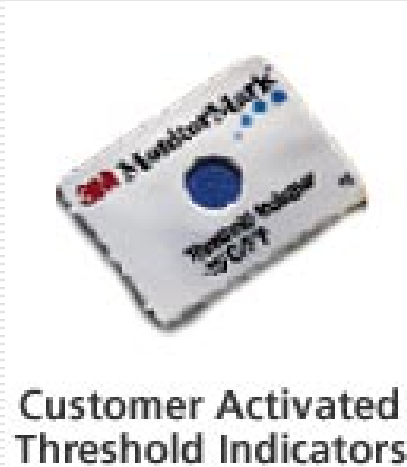

Activation strip

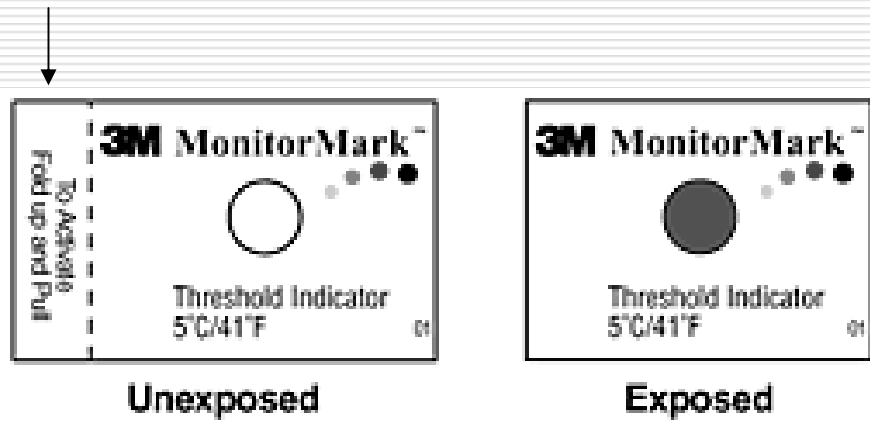

Upon exposure to temperatures above the threshold, the activated indicator's window irreversibly turns blue.



# 3M MONITORMARK TTI

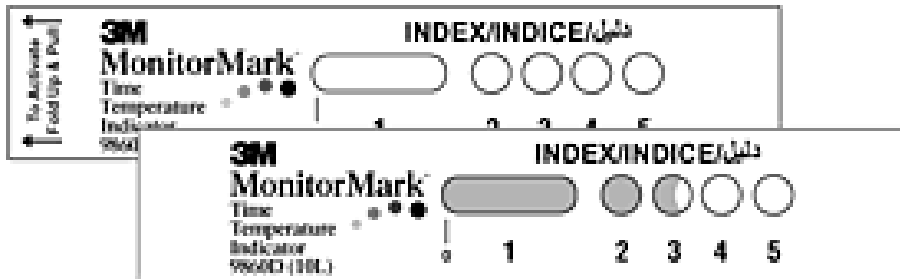
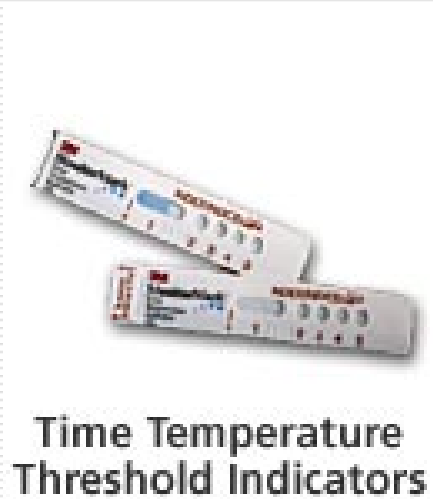

The diffusion of a dye is the indicator

The MonitorMark time temperature indicator contains a porous wick indicator track strip, one end of which is positioned over a reservoir pad containing a blue dyed chemical with a desired melt point.



# Vitsab Single Dot Label (TTI)

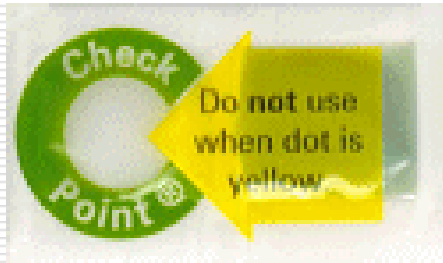

Central raised portion (pouches)  
pre-activation = 0.080"  
post-activation = 0.060"

0.08" label thickness  
(including adhesive layer)

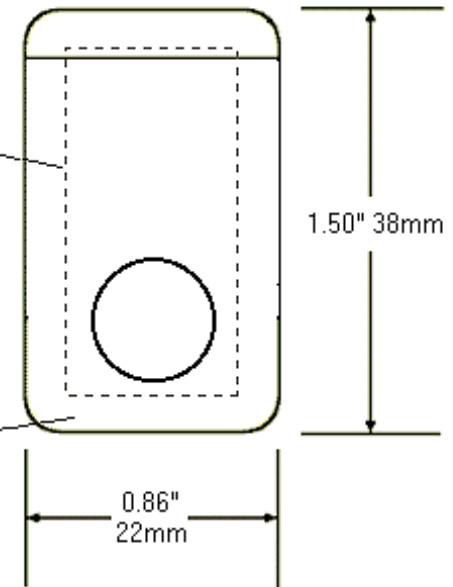

Single dot Vitsab's CheckPoint™ brand labels: (1) distribution temperature monitoring of cartons or pallets of product, and (2) distribution or consumer package unit.



# INTELLIGENT PACKAGING

---

- Food preservation
  - Senses the age, quality level of the food and signals
  - Signals on exterior of food storage area
  - Has been demonstrated in laboratory
  - Usually a secondary measurement
    - Measures time/temperature
    - Signals based on history
  - Publicized as mechanism to incorporate tighter temperature controls into distribution channels



# SHELF LIFE SENSING

---

- Developmental
  - RFID remote sensor
  - Chipless with internal paper battery
  - Smart active label – SAL – with chip
  - Can be added to logistic sensor
  - Sense time temperature
  - Send signal to reader
  - Display time temperature record or integral



# Food: Microbiological Growth/Spoilage Indicators

---

- ❑ Rapid microbiological indicators do not exist in real commercial world
- ❑ Rapid microbiological spoilage sensors do not exist in commerce
- ❑ Rapid microbiological pathogen indicators do not exist in commercial world
- ❑ Consumer smell, observations and judgment are today the best signals of food spoilage or hazard.
  - Do instrumental, etc. sensors truly reflect spoilage?
- ❑ Alternative is tedious laboratory analysis



# BIOSENSORS

---

- Biomolecular recognition
  - Antigen-antibody
  - Phage capture
    - Spores
    - Bacteria
    - Higher capture rate than antibodies
  - Both highly specific



# BIOSENSORS

---

## □ Sensor platforms

- Acoustic wave
  - Thickness shear quartz resonator
  - Microcantilevers
    - Laser measured
  - Flexure plate wave devices
    - Piezoelectric actuated
  - Piezoelectric polymer devices
  - Microelectric-mechanical-magnetostrictive devices
- All require on-board power and connection to RFID



# BIOSENSORS

---

- Sensor platforms
  - Surface plasmon
  - Magnetostrictive
    - Integrated with antibody/phage layer
    - Oscillation
    - Produces magnetic field signal



# Food: Microbiological Growth/Spoilage Indicators

---

- The former Cox Technologies
  - Respond to amine and sulfide volatiles from spoilage
  - Used to colorimetrically signal seafood microbiological spoilage
  - Commercial



# Ripeness Sensors

---

## ripeSense Label

- Reportedly senses aromatics emitted from ripening fruit
- Signals ripeness by label visual cue/color change – for fruit that does not change color during ripening
  - Pears
  - Melons
  - Avocados



# UPC (Universal Product Code) Bar Codes

UPC of 12 oz can of Coke

©2000 HowStuffWorks



The first digit of the manufacturer is called the number system character: 0 for standard UPC number, 2 for random weight items (fruits, vegetables, meat), 3 for pharmaceuticals, etc.

Manufacturer ID  
(6 digits)

Item Number  
(5 digits)

Check Digit  
(1 digit)



# PDF 417 Symbol (2-Dimensional)

---

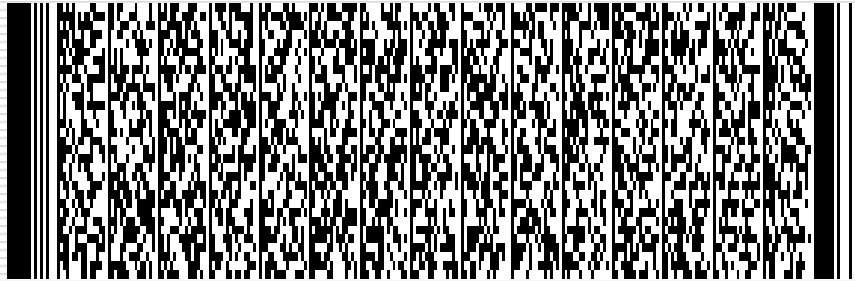

- ❑ PDF417 is a two-dimensional symbol
- ❑ It can carry up to 1.1 kilobytes of machine-readable data in a space no larger than a standard bar code.
- ❑ A PDF scanner is required to require PDF symbols. Ordinary bar code scanners would not work.
- ❑ PDF stands for “Portable Data File”



# INVENTORY “CONTROL”

---

- ❑ Determine the presence, absence or impending decrease in quantity of a packaged food in pantry/refrigerator inventory
- ❑ Signal consumer that the pantry is empty or near empty
  - Alert consumer to restock
- ❑ Signal retail grocer that Mr./Mrs./Ms. X is low on product and to remind her/him by telephone, e-mail or by sending replenishment stock
- ❑ Signal distribution center that the stock is low or out
- ❑ Indicator on package as empty package is discarded
- ❑ Active signaller – or messenger to grocer - on package as empty package is discarded



# INTELLIGENT PACKAGING FOR THE HOME/FOOD SERVICE OPERATOR

---

- Inventory control
  - Tracks inventory of food in home
  - Senses when empty package is discarded
  - Places tentative order with retailer /delivery service
    - Confirm by consumer
  - Complemented by interaction with retailer
    - Special requests
    - Change order schedule



# INTELLIGENT PACKAGING FOR THE HOME/FOOD SERVICE OPERATOR

---

- Provides product information
  - Recipe specific to consumer's "kitchen" equipment
  - Nutritional characteristics
    - Beyond reading the label
    - Integrates individual consumer's nutritional needs
    - Takes into account the age and time/temperature experience
    - Overtly signals the individual consumer as to dietary value



# INTELLIGENT PACKAGING FOR THE RETAILER

---

- ❑ Automatic self-check out
- ❑ No direct reading by scanner
- ❑ RDID or equivalent
  - Printed on package
  - Read remotely as consumer moves out of retail establishment
  - Totals all items acquired
  - Debits consumer account
  - No movement of product from “shopping cart”
- ❑ Automatic shelf price change



# INTEGRATE PACKAGING WITH APPLIANCES

---

- Many attempts to integrate food packaging and food heating appliances
  - Generally few successful marriages
  - Microwave reheating for home meal replacements
    - But not appliance specific
    - Do not accommodate to the wide variety of microwave ovens
  - Other appliances
    - Toaster ovens
    - Refrigerators
    - Coffee brewers



# FOOD PREPARATION: MICROWAVE

---

- Microwave ovens
  - Major differences in ovens
    - Power levels
    - Distribution of energy
    - Age of oven
  - Major differences in energy absorption
  - Microwave heating now judged by operator
  - Automatic control integrates food, package and oven



# COOKING/HARDWARE

---

- Trends
  - Multi-modal heating
    - Single mode too limiting
- Multi-modal cooking
  - Consumer education
  - Cost higher than conventional
  - Food processor/packager involvement
    - Not all foods can be prepared in multi-modal ovens
- High speed oven
- Smart ovens



# SMART OVENS

---

- ❑ Because new energy source ovens cook differently, automatic operating controls are required
- ❑ Convert from conventional recipes and cooking instructions
- ❑ Download recipes from internet since consumers will need directions



# HEALTH MONITORING

---

- ❑ Records the food intake by the consumer. Display a summary of food intake, nutritional and other information.
- ❑ Connecte to an electronic scale for monitoring the weight of the consumer.
- ❑ Provide the consumer useful suggestions based on the above information. The information may also be transmitted to the doctor's office.



# THE FUTURE

---

- Food shelf life will be shorter
- Time in home will be shorter
- Food preservation and preparation will integrate with packaging
  - Packaging will be integrated with processing and distribution
  - Package will be a preparation **and** serving aid



# NEEDS FOR THE FUTURE

---

- Visible inventory communication for refrigerated and frozen foods
  - Age
  - Time temperature integral
    - Possible quality signal
  - Overt signal to consumer



# NEEDS FOR THE FUTURE

---

- Cooperation among food processors, retailers which offer prepared foods
  - Product packaging to fit home processing
  - Instruction
  - Linkage by computer sensor read and response
  - Long term program



# THE FUTURE

---

- Long term
  - Accurate information
    - Target each household member individually
    - Quality
      - Flavor, mouth feel
      - Nutrient value
      - Other value
    - “Spoilage”
    - Preparation directions based on food, consumer and in-home equipment/interface
  - Communication channel/message





**THE FUTURE IS PURCHASED  
BY THE PRESENT**

SAMUEL JOHNSON

# STATE OF THE ART OF ACTIVE/INTELLIGENT FOOD PACKAGING

---

Aaron L. Brody  
Packaging/Brody, Inc.  
P O Box 956187  
Duluth, Georgia 30095 USA

Institute of Food Technologists  
Food Packaging Summit  
7-9 May 2006

